

# AR40 Assistrail® Disability Handrail Specifications

## Single Inline Handrail / Midrail & Kerbrail

For disabled ramps under one metre (FFL) and midrail for extra protection



### Key features

- > Modular flexibility
- > No-weld assembly
- > Flat pack delivery
- > Reduced corrosion
- > Colour options
- > Available ex-stock
- > BIM & CAD Support

### Applications suited to

- > DDA access ramps and stairs
- > Fire and access stairs
- > Aged care and accommodation
- > Hospitals, schools, universities
- > Public transport and sightseeing
- > Community and recreation centres

### Specification Summary

Supply and install the proprietary AR40 handrail system to substrate according to Moddex specifications, or by a Moddex accredited installer.

### Technical Data

#### Material

Stanchions & rails		Steel/grade C250 & 350
Kerb Rail		Aluminium Extrusion (with EPDM Separation pads)
Clamp fittings		Malleable Cast iron
Clamp locking screws		Stainless Steel (304)
Protective coating		
Stanchions & rails		G390 Hot-dip Galvanized (min 390g/m <sup>2</sup> )
Clamp fittings		Hot dipped galvanized with patented protective coating on threads
Optional		Powder coating and paint specs*

\* The standard process for Powder Coated and Painted handrail products is as follows: black steel is used for fabrication. The steel is sand blasted and a zinc primer coating is applied. The powder coat / paint coat is then applied over the zinc primer creating a dual shield coating with a decorative finish.

### Dimensions

Variable depending on building/application/ code

#### Stanchions

Diameter	48.3mm OD 41.9mm ID
Nominal Thickness	3.2mm - 4.0mm (loading dependent)

#### Rails

Diameter	48.3mm OD 41.9mm ID
Nominal Thickness	3.2mm

#### Clamp fittings

Thickness	5.0mm (approx)
Locking screws	M12 x 1.75 x 11mm - DEXX Drive

#### Kerb Rail

Height	122mm
Width	24mm

### Weight

Variable depending on building/application/ code

Stanchion with clamps	7.2 to 8.0kg
Rail @ 6.0m	21.6kg

### Fixings

Stanchion attachment to

Concrete	M12 galvanized mechanical concrete anchor
Structural steel	M16 galvanized high tensile bolt set

\*Other Fixing options are available on request

### Compliance

Moddex AR40 handrails are designed and manufactured in accordance with Australian Standard AS 1428.1-2009 and relevant statutory WHS Codes of Practice/ Guidelines.  
Galvanized to AS/NZS 4680:2006

### Testing

Testing and performance based on requirement of Australian Standard AS1170.1 Clause 3.6 Table 3.3. Stringent vibration endurance tests have been performed

### Warranty

5 years from date of purchase subject to correct installation, use and maintenance in accordance with manufacturer's specifications and recommendations, unless otherwise negotiated at the time of purchase.

— Refer maintenance manual

### Inspection & Maintenance

Visual inspection for any damage or loose fixings must be done periodically and prior to use. No certified maintenance required. Basic wear and tear preventative maintenance is recommended, as per manufacturer's specifications and recommendations.

— Refer maintenance manual

## Technical Information

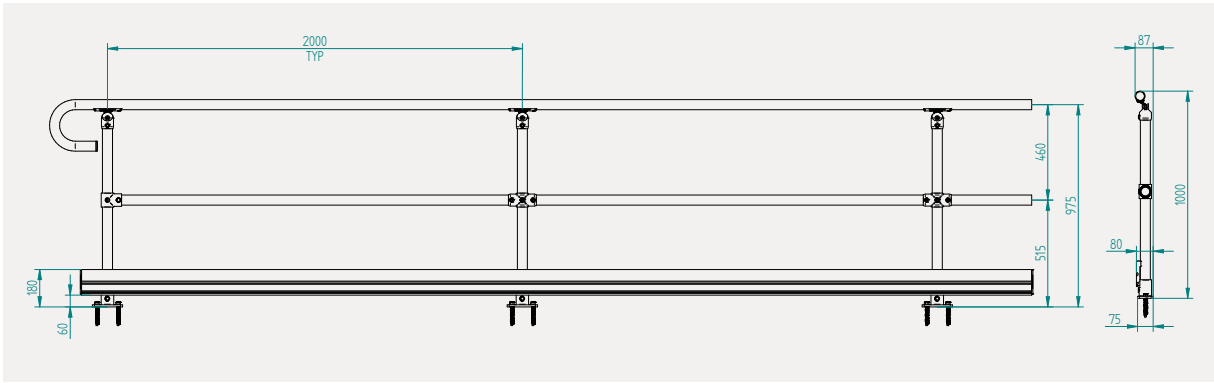

## Mount Dimensions

T2 - Top Mount (2 Fixings)	F2 - Face Mount (2 Fixings)	CL - Channel Mount (2 Fixings)
GD - Inground Mount	CD - Cored Mount	AM - Angle Mount

## Standard References

Excerpt from Australian Standard AS 1428.1:2009

- 10.3 (e) Ramps shall have a handrail complying with Clause 12 on each side of the ramp
- 10.3 (i) Ramps and intermediate landings shall have kerb rails on both sides that comply with the following:
- The minimum height above the finished floor shall be 65mm.
  - The height of the top of the kerb or kerb rail shall not be within the range 75mm to 150mm above the finished floor.
  - There shall be no longitudinal gap or slot greater than 20mm in the kerb or kerb rail within the range 75mm to 150mm above the finished floor.
- 12 (i) Handrails shall have no obstruction to the passage of a hand along the rail.

Important Note: Failure to supply and/or install proprietary product in accordance with above Standards and codes, specification and instructions, voids complete system certification and/or warranty.

Designed and manufactured by Moddex Systems. ©Moddex Group. All Rights Reserved.

For information or technical support please contact us  
 T 1800 663 339 (AU)  
 0800 663 339 (NZ)

moddex.com.au