

AR140 Assistrail® Disability Handrail Specifications

Twin Double Offset Handrail

For Class 9b buildings used for primary schools



Key features

- › Modular flexibility
- › No-weld assembly
- › Flat pack delivery
- › Reduced corrosion
- › Colour options
- › Available ex-stock
- › BIM & CAD Support

Applications suited to

- › DDA access ramps and stairs
- › Fire and access stairs
- › Aged care and accommodation
- › Hospitals, schools, universities
- › Public transport and sightseeing
- › Community and recreation centres

Specification Summary

Supply and install the proprietary AR140 handrail system to substrate according to Moddex specifications, or by a Moddex accredited installer.

Technical Data

Material

Stanchions & rails	Steel/grade C250 & 350
Clamp fittings	Malleable Cast iron
Clamp locking screws	Stainless Steel (304)

Protective coating

Stanchions & rails	G390 Hot Dip Galvanized (min 390g/m ²)
Clamp fittings	Hot-dip Galvanized with patented protective coating on threads
Optional	Powder coating and paint specs*

* The standard process for Powder Coated and Painted handrail products is as follows: black steel is used for fabrication. The steel is sand blasted and a zinc primer coating is applied. The powder coat / paint coat is then applied over the zinc primer creating a dual shield coating with a decorative finish.

Dimensions

Variable depending on building/application/code

Stanchions

Diameter	48.3mm OD 41.9mm ID
Nominal Thickness	3.2mm

Rails

Diameter	48.3mm OD 41.9mm ID
Nominal Thickness	3.2mm

Clamp fittings

Thickness	5.0mm (approx)
Locking screws	M12 x 1.75 x 11mm - DEXX Drive

Weight

Variable depending on building/application/code

Stanchion with clamps	7.2 to 8.0kg
Rail @ 6.0m	21.6kg

Fixings

Stanchion attachment to

Concrete	M12 galvanized mechanical concrete anchor
Structural steel	M16 galvanized high tensile bolt set

*Other Fixing options are available on request

Compliance

Moddex AR140 handrails are designed and manufactured in accordance with Australian Standard AS 1428.1-2009 and relevant statutory WHS Codes of Practice/Guidelines.
Galvanized to AS/NZS 4680:2006

Testing

Testing and performance based on requirement of Australian Standard AS1170.1 Clause 3.6 Table 3.3. Stringent vibration endurance tests have been performed

Warranty

5 years from date of purchase subject to correct installation, use and maintenance in accordance with manufacturer's specifications and recommendations, unless otherwise negotiated at the time of purchase.

— Refer maintenance manual

Inspection & Maintenance

Visual inspection for any damage or loose fixings must be done periodically and prior to use. No certified maintenance required. Basic wear and tear preventative maintenance is recommended, as per manufacturer's specifications and recommendations.

— Refer maintenance manual

Technical Information

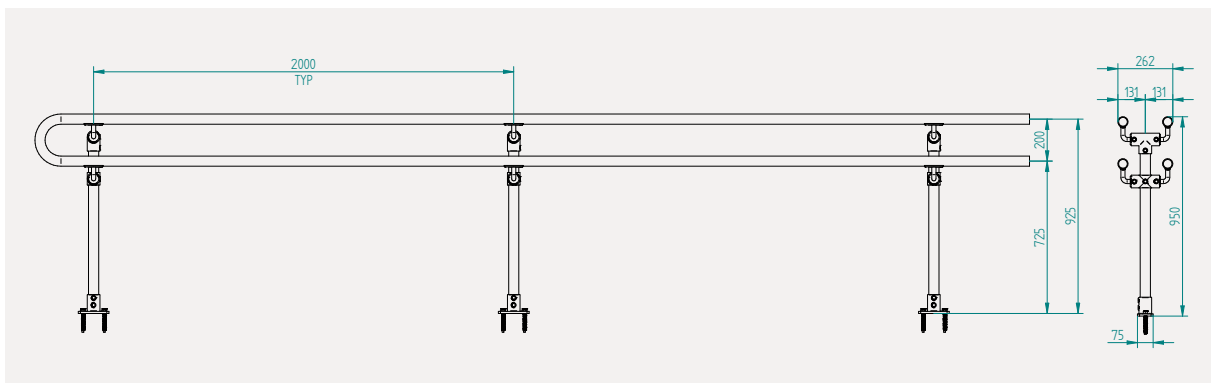

Mount Dimensions

T2 - Top Mount (2 Fixings)	F2 - Face Mount (2 Fixings)	CL - Channel Mount (2 Fixings)
GD - Inground Mount	CD - Cored Mount	AM - Angle Mount

Standard References

Excerpt from Australian Standard AS 1428.1:2009

- 12 (b) The cross-section of handrails shall be circular or elliptical, not less than 30 mm or greater than 50 mm in height or width for not less than 270° around the uppermost surface as shown in Figures 29(a) and 29(b). Elliptical handrails shall have the greater dimension in the horizontal axis as shown in Figure 29(b).
- 12 (d) The top of handrails shall be not less than 865 mm nor more than 1000 mm above the nosing of stairway tread or the plane of the finished floor of the walkway, ramp or landing.

Important Note: Failure to supply and/or install proprietary product in accordance with above Standards and codes, specification and instructions, voids complete system certification and/or warranty.

Designed and manufactured by Moddex Systems. ©Moddex Group. All Rights Reserved.

For information or technical support please contact us
 T 1800 663 339 (AU)
 0800 663 339 (NZ)

moddex.com.au